

ADVANCED OPTICAL INSTRUMENTATION METHODS

G. F. HEWITT and P. B. WHALLEY

Engineering Sciences Division, A.E.R.E. Harwell, Oxfordshire OX11 0RA, England

Abstract—Optical instrumentation methods are now used very widely in two-phase flow systems. A classification of optical methods is first presented and then two general areas of optical technique are surveyed. The first of these areas is that of local, remote, measurements using laser scattering and related techniques. Here, reference is made to the use of scattering methods for drop size, for local velocity and for local concentration and temperature. The second area covered is that of advanced photographic methods and specifically the axial view technique. The development of this technique and its applications are discussed and a new variant of the technique (laser shadowgraph method) is described. Results obtained in the application of this technique to annular flow and to flooding in counter-current flow are presented. The annular flow measurements show that there is considerable persistence of initial velocity of large drops emitted from the liquid film in annular flow. The studies of flooding reveal that the flooding phenomena is caused by rapid growth of large waves on the film interface which burst, giving rise to the creation of droplets and the transfer of liquid upwards beyond the injection point.

1. INTRODUCTION

Methods of measurement in two phase flow systems involving modulation of beams of photons are very widely used. In this present review, we will be concerned with photon beams in the visible frequency range (light) though the application of photon beams is by no means restricted to this range of frequencies. Perhaps the most commonly used technique in two-phase flow is that of gamma beam absorption and photon beams of frequency less than that of visible light have also been used (e.g. micro-waves and IR).

There are many ways of classifying the various techniques employed in two phase flow using photon beams; for illustration, we have chosen the classification shown in table 1. This is in terms of:

- (1) The light modulation process: absorption, scattering, interference, refraction, excitation and complex combined modulation effects.
- (2) The recording method: this can either be electronic (using, for example, photo-diodes or photo-multipliers) or photographic.

Table 1. Classification of optical techniques

Light modulation process	Method of recording	
	Electronic	Photographic
Absorption	Film thickness, void fraction (X, γ -ray), concentration (infra-red)	X-radiography, γ -radiography
Scattering	Drop size	Drop size (holography), Axial view (laser)
Interference	Velocity (LDA)	Concentration, temperature (includes holographic interferometry)
Refraction	Void fraction (phase sensors)	Schleiren photography shadowgraph
Excitation	Fluorescence method	Phosphorescence (velocity profile)
Complex	Raman Velocity (correlation)	Visual photography, axial view (ordinary)

It is beyond the scope of the present review to give details of all the various techniques listed in table 1. However, a comprehensive review is available of most of the techniques in the book by Hewitt (1978a). Here, we will concentrate on two areas: (i) advanced laser instrumentation for drop size and local concentration and temperature, and (ii) advanced axial view photography methods for annular and related flows. The first of these two areas is selected in view of the very great amount of work that has been done in the area over the past five years. It is now becoming possible to make detailed, continuous and accurate local measurements of many two phase flow parameters using these techniques. However, the use of cine-photographic methods (and particularly axial view techniques) can give a much better physical insight into the processes occurring than can normally be obtained from point measurements, albeit that these measurements give much more quantitative results.

2. LOCAL PARAMETER MEASUREMENT USING LASER METHODS

2.1 Drop size

Light scattering methods for the measurement of drop size and bubble size in two phase flow have been widely applied for many years. A review of some of the earlier methods is given by Hewitt (1978a); recently, it has become possible to make drop size distribution measurements using this technique in a much more convenient manner. One such development is that reported by Swithenbank *et al.* (1976) and a commercial unit using this technique is available (Malvern Instruments Ltd., U.K.). This method has recently been applied to drop size measurement in annular flow by Azzopardi *et al.* (1978) as illustrated in figure 1. The liquid film is separated and the remaining droplets flow with the gas through the laser beam which enters and leaves through the window system. The beam is defracted at a small forward angle as illustrated and falls on a detector consisting of a series of annular rings. The distribution of intensity over the respective rings can be processed to give a drop size distribution. The system operates in a drop size range typically 5–500 μm and data obtained by the method are illustrated in figure 2. As will be seen, for a given gas flow rate, the drop size is relatively insensitive to liquid flow rate over the range covered.

Information produced by scattering methods of the type illustrated in figure 1 has a number of limitations:

(1) A drop size distribution form has to be assumed in processing the results. For instance, Azzopardi *et al.* (1978) used the Rosin–Rammler two parameter distribution equation. This equation was found to fit earlier, photographically obtained, drop size distribution data closely but, nevertheless, the need to have a drop size distribution equation in processing the results is a limitation.

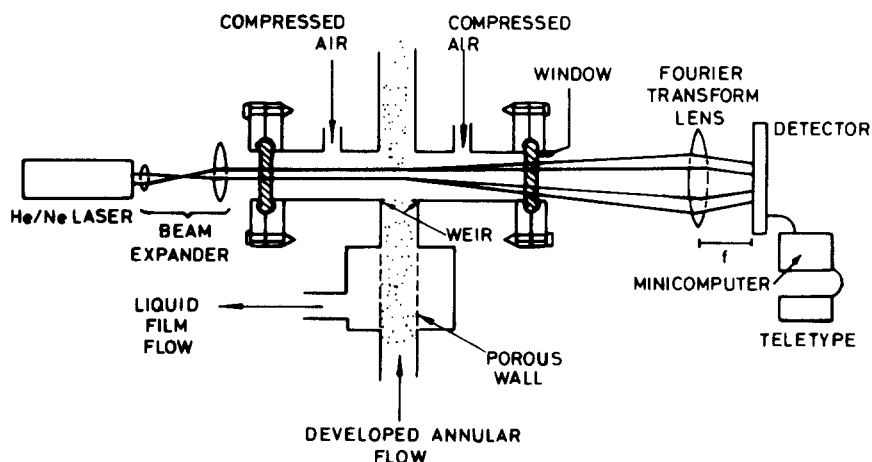

Figure 1. Defraction method for dropsize determination in annular flow. (Azzopardi *et al.* 1978.)

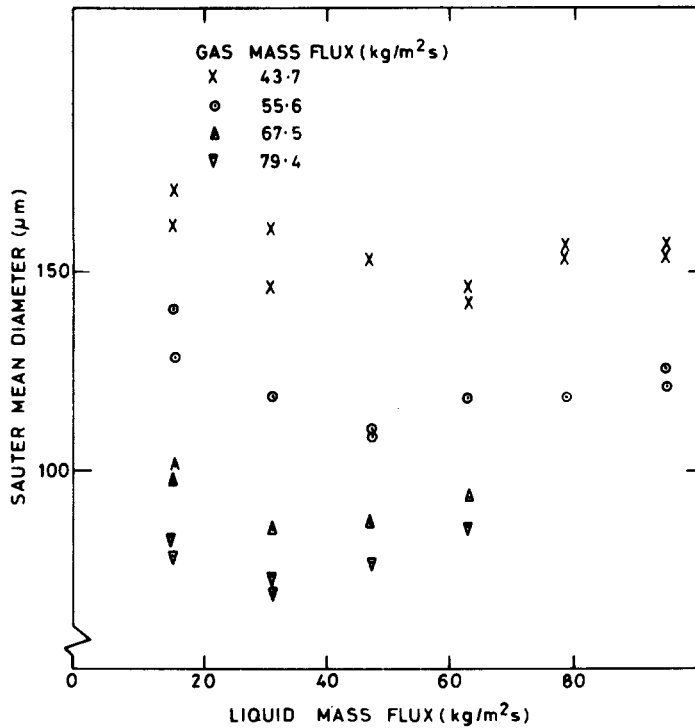

Figure 2. Dropsize distribution data for air-water annular flow at atmospheric pressure. (Azzopardi *et al.* 1978.)

(2) The only information obtained is on drop size and there is no information on the spacial distribution of drop size within the channel. Also, there is no information on the velocity of drops of varying sizes.

Clearly, it would be helpful in an understanding of two phase drop flows if information were available on the distribution of the various components of velocity associated with the various drop sizes. This information is, of course, highly sophisticated but it is now becoming possible to obtain it using methods derived from laser doppler anemometry (LDA).

The principle of LDA is illustrated in figure 3. A laser beam is split into two separate beams and the beams are focussed to intersect at the required measurement point. At this point an interference fringe pattern is produced. Light scattered by the particles moving through the

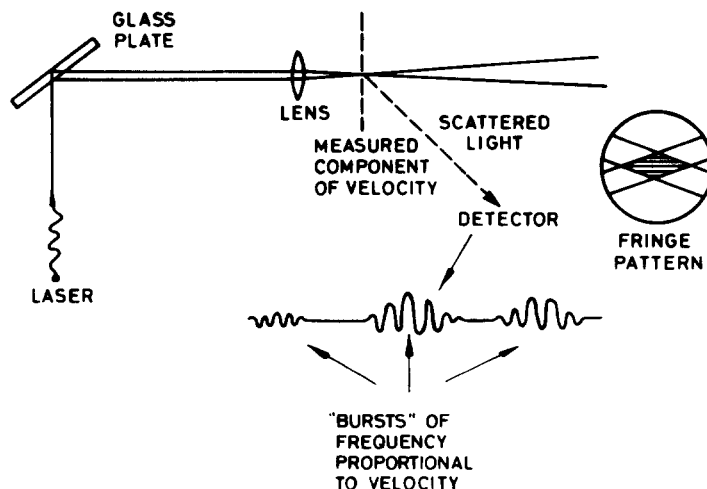

Figure 3. Fringe method for laser anemometry measurement of local velocity.

fringes is intensity-modulated at a frequency which is proportional to the velocity component normal to the fringes and inversely proportional to the fringe spacing. This modulation can be detected in light scattered in any direction from the fringes and is produced as an a.c. component at the modulation frequency in the output of a detector in any position relative to the beams. As particles pass through the beams, they give "bursts" of signal as illustrated in figure 3. For the particle passing through the centre of the scattering volume at the point of intersection at the beams, the amplitude of the envelope of the "burst" increases with droplet size. Among the difficulties of using this phenomenon to detect droplet size are:

(1) Bursts of a given amplitude may arise from a particle passing through the centre of the scattering volume, or from a larger particle passing off-centre through the scattering volume.

(2) In any technique which depends on absolute amplitude measurement, there are problems of calibration due to variations in absorption in window and other optical components.

The first of these problems has been overcome by Prof. S. L. Lee *et al.* at Stony Brook (see e.g. Lee & Srinivasan 1978). Here, a sophisticated data processing technique is used which detects the velocity of the particle and, simultaneously, the residence time of the particles in the scattering volume. This allows the determination of the length of the track through the scattering volume and only those signals where the length of the track corresponds to trajectories through the centre of the scattering volume are accepted. Figure 4 shows a calibration curve obtained by Lee & Srinivasan (1978) for signal amplitude as a function of drop size. Using this technique, it has been possible to obtain local drop size distributions together with correlated measurements of the various components of velocity.

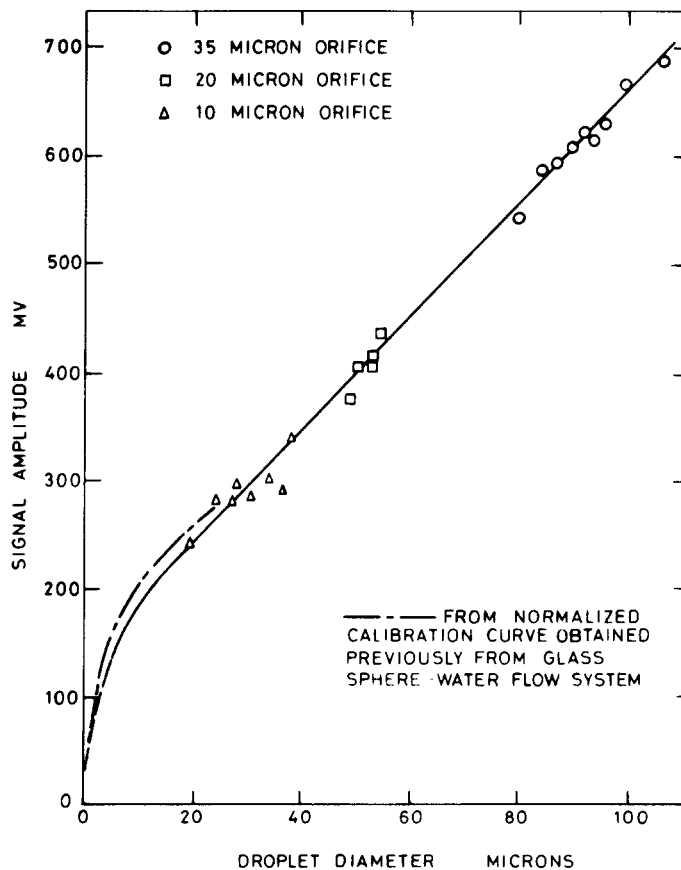

Figure 4. Relation between laser doppler anemometer burst amplitude and dropsize. (Lee & Srinivasan 1978.)

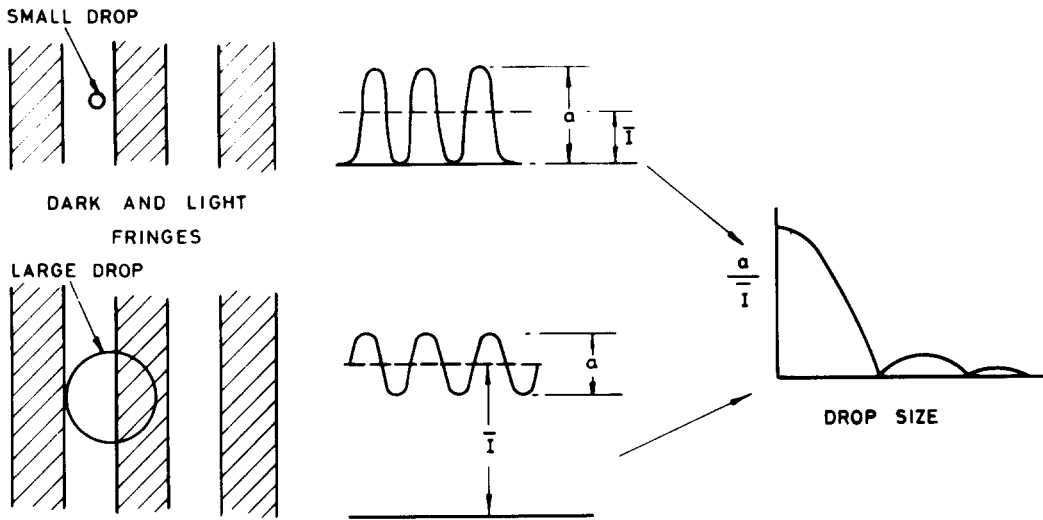

Figure 5. The Farmer (1972) visibility technique for droplet size measurement.

A technique which overcomes the problem of obscuration of windows and other optical components is the so-called “visibility” technique of Farmer (1972) which is illustrated in figure 5. A droplet of diameter small compared with the fringe spacing generated at the beam crossing point in a laser anemometry system, will give a scattering signal fluctuating between zero intensity and the maximum amplitude. A larger droplet, on the other hand, will always lie partly within one of the light fringes and will always be scattering to some extent, though the scattered intensity will also be modulated at a frequency dependent on the droplet velocity. The basis of the Farmer visibility technique is that the ratio of the modulation amplitude (a) to the average intensity (\bar{I}) is a function of drop size as sketched in figure 5. Thus by measuring both the amplitude of the modulation and the mean intensity of the scattered light, an estimate of the drop size can be obtained. Due to the nature of the signal, there is an ambiguity of the response for particle sizes greater than 1.05 fringe spacings. In a typical application of the technique (Schmidt *et al.* 1976) this limit corresponded to a drop size of about $90 \mu\text{m}$.

A system for simultaneous drop size and velocity measurement which can be used for larger drops is described by Wigley (1978), and is illustrated in figure 6. A droplet passing through the scattering volume (the intersection volume of the two laser beams) gives a back-scattered modulated signal from which the velocity can be deduced in the normal way. Forward

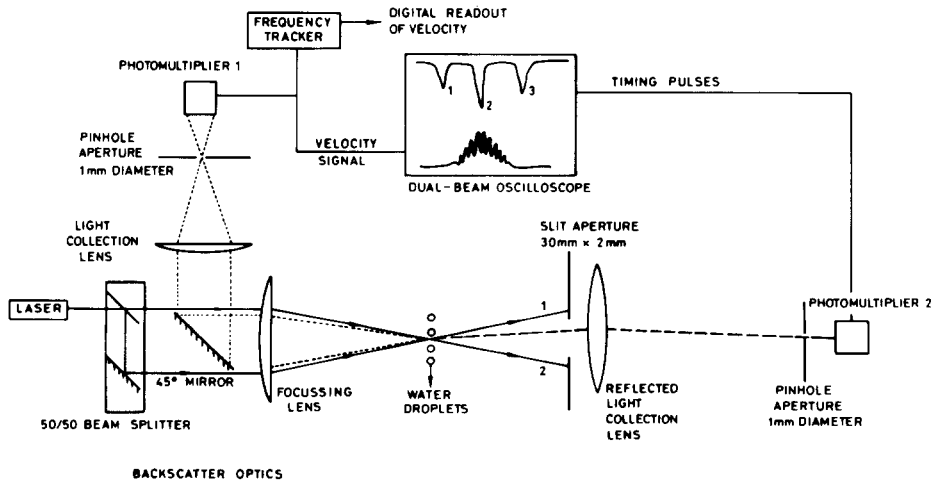

Figure 6. Technique for simultaneous drop velocity and droplet size measurement (Wigley 1978).

scattering of the beam also occurs and the forward scattered signal shows three peaks from the leading edge, centre and trailing edge of the droplet respectively. By using a slit aperture, it is possible to avoid signals from all droplets which do not pass axially through the beam intersection point, thus avoiding ambiguity. Since the velocity is known from the modulated back-scattered signal, the time interval between the first and the third peaks multiplied by the velocity gives the droplet diameter. Though it is quite straightforward to measure the droplet size from photographic records of the received signals, it is more difficult, with this technique, to develop an automatic processing system.

Clearly, laser drop sizing methods are already providing interesting new evidence on flow with drops. However, there are still optical access and signal processing problems which make these techniques expensive and difficult to apply. In the next few years, we may anticipate much further development in this area.

2.2 Laser Raman spectroscopy for local temperature and concentration measurement

A technique which is likely to assume increasing importance in the future for local and remote concentration and temperature measurement in fluids is that of laser Raman scattering. The principle of the Raman scattering method is illustrated in figure 7.

If a fluid is irradiated with a laser beam of frequency ω_1 ; the beam interacts with the molecules of the substance, exciting these molecules from the ground state to a virtual state, A (see figure 7a). The molecules then return from the virtual state A re-emitting light; most of this re-emission is at the original frequency ω_1 , but a proportion of the re-emission occurs due to the molecule returning from state A to a vibrational level which has an effective frequency difference Δ from the ground state. The emission corresponding to this latter transition has a frequency $\omega_s = \omega_1 - \Delta$. The emission at frequency ω_s is called the "Stokes emission". Depending on the temperature, molecules already exist within the vibrational level and these themselves can be excited to a virtual state B by the laser irradiation (see figure 7b). If there is a return from state B to the ground state then emission occurs at the so-called anti-Stokes frequency $\omega_{as} = \omega_1 + \Delta$. By examining scattered light arising from a point along the laser beam length (within the fluid) and by determining the intensity of the scattering at ω_s or ω_{as} , it is possible to determine the local concentration of the molecular species. Since the population of the vibrational state is dependent on temperature, the local temperature of the fluid can be determined from the ratio of the intensities of the anti-Stokes and Stokes emissions.

Though it is a very powerful technique for remote detection of average local concentration and temperatures, the main problem with the conventional Raman technique is that the Raman

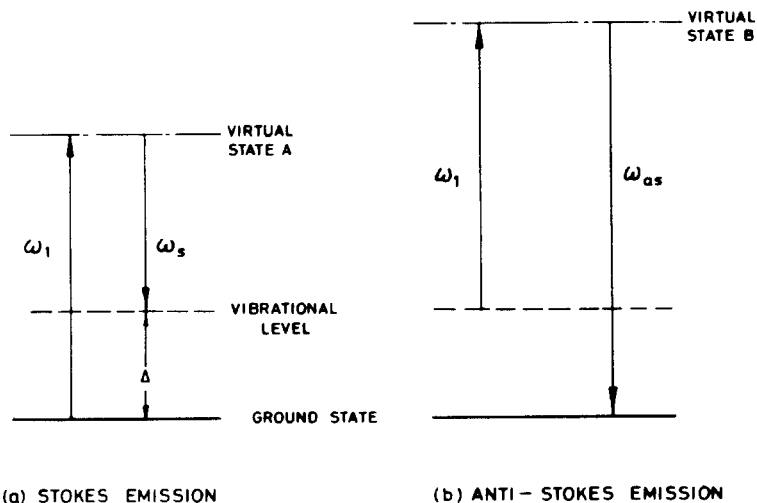

Figure 7. Principle of Raman scattering method for temperature and concentration measurement.

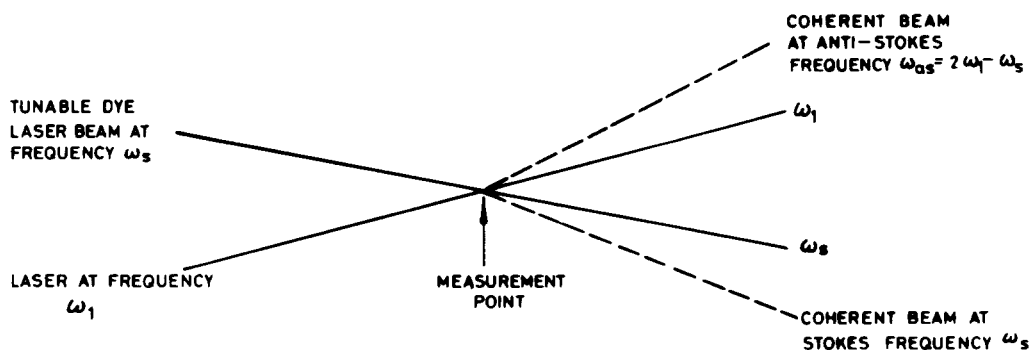

Figure 8. Coherent anti-Stokes Raman scattering (CARS) system.

scattering is itself very weak and long times (e.g. 10 min) are required to obtain accurate values. From the point of view of measuring two phase flow systems, this would have made the Raman spectroscopy system of only academic interest. However, a technique has been developed recently which allows measurements to be made (using a pulsed laser) in times of the order of nanoseconds. This technique is known as CARS (coherent anti-Stokes Raman scattering) and is illustrated schematically in figure 8. A laser beam of frequency ω_1 is intersected with a beam from a tunable dye laser at the Stokes frequency ω_s at the point where the measurement is required. This results in the creation of two coherent beams, at the anti-Stokes and Stokes frequencies, which emerge from the system with an angular displacement relative to the incident beam as shown. The fact that these beams are coherent and separated from the incident beams means that rapid and sensitive measurements can be made.

A review of laser Raman diagnostic techniques is given by Williams & Stenhouse (1978) and further detailed information is given in the papers of Regnier (1973), Begley *et al.* (1974), Regnier *et al.* (1974) and Nibler *et al.* (1976). It may be expected that these techniques will be used in a whole variety of two phase flow experiments in future years.

3. AXIAL VIEW PHOTOGRAPHIC TECHNIQUES

Although much can be learnt about two phase flows by photographing the flow in transparent tubes in a direction normal to the flow, such techniques do not give information on the radial motion of the fluids. Furthermore, the view is dominated by phenomena occurring close to the wall. For annular and related flows, complementary information can be obtained by using axial view techniques. In this section, we describe the earlier development of these techniques where the view is concentrated in a relatively shallow depth of field. We also present a new development of the technique which gives a much greater depth of field and allows the study of droplet radial motion over long distances.

3.1 Axial view methods with small depth of field

The original version of the axial view method, as described by Arnold & Hewitt (1967), is illustrated in figure 9. An annular flow is passing up a vertical tube and a short section of the tube is illuminated as shown. The illuminated zone can be viewed through a window above which is positioned a high speed cine-camera, which is focussed on the plane of illumination, as shown. The window is kept free of liquid by passing an air purge over it and down the "viewing tube" as illustrated. The fluids passing up the channel are diverted into an exit chamber and then, via return pipes, to the separation tank.

Using the axial view technique, it is possible to obtain a "cross section" of, for example, an annular flow where the circumferential distribution of the liquid film can be clearly seen, and the creation and movement of droplets within the plane of illumination (the object plane) observed. The technique has been applied extensively to the study of annular flow in vertical

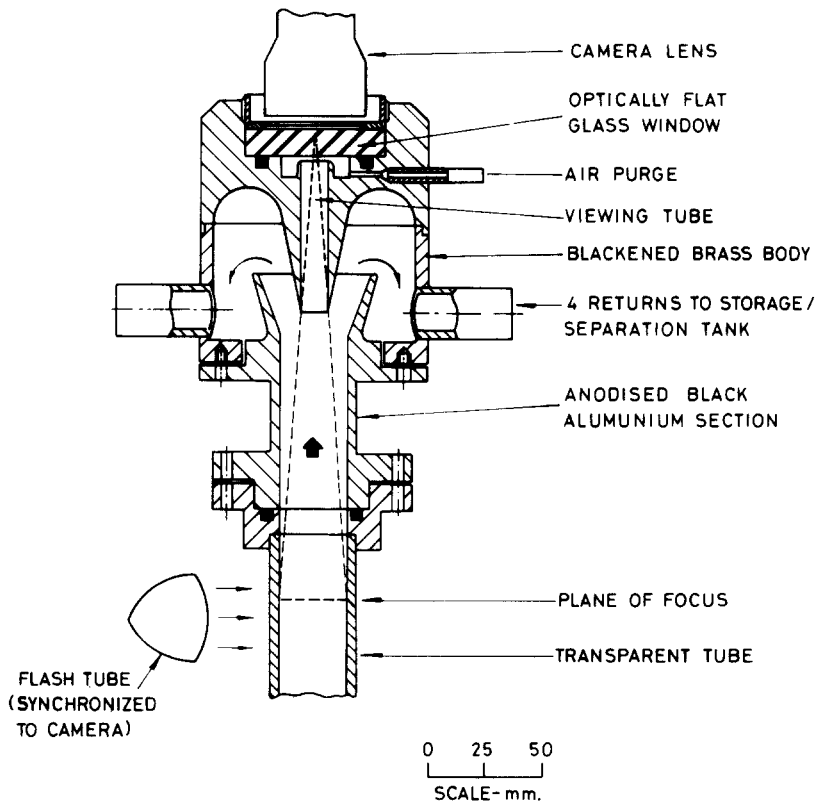

Figure 9. Device for axial-view photography of annular two-phase flow. (Hewitt & Roberts 1969.)

tubes (Hewitt & Roberts 1969), for horizontal air-water and one-component Refrigerant-12 flows (Fisher & Yu 1974, Coney & Fisher 1976 and Fisher *et al.* 1978) for counter-current flow and flooding in vertical tubes (Suzuki & Ueda 1977) and for evaporating Refrigerant-12 flows in vertical tubes (Langner & Mayinger 1978 and Langner 1978). In the latter experiments, quantitative analysis of the photographs allowed determinations of the local radial velocity and the flow rate of the entrained phase.

Further developments of the axial view technique are reported by Whalley *et al.* (1977). The main changes from the original technique were as follows:

(1) The viewing section was not mounted concentrically with the main flow tube but was inclined at an angle of 8° . This allowed viewing of the surface of the liquid film and a clearer visualisation of the entrainment mechanisms.

(2) In the original method, only a 6 mm length of tube was illuminated; in the experiments of Whalley *et al.* the length illuminated was increased to 100 mm and, although the full length was not in sharp focus, due to the limited depth of field, a better impression of the events taking place could be obtained.

(3) A stereoscopic axial view technique was developed, the principle of which is illustrated in figure 10. Here, two viewing tubes are used with viewing directions arranged such that they intersect in the plane of illumination, at a point close to the tube wall. Images obtained via the respective tubes are recorded side-by-side on cine-film thus forming a stereoscopic pair from which it should be possible to reconstruct the three-dimensional motions of the phases. Although some interesting pictures were obtained using this technique, it has been found difficult to process the information to obtain data on the radial motion of the drops. In particular, the stereoscopic nature of the image is limited to a rather narrow region.

One of the main difficulties with axial view photographic techniques (and indeed with most photographic techniques for two phase flow) is the need to process and interpret complex images produced in the photography. Thus, droplets seen in the plane of focus may arise locally

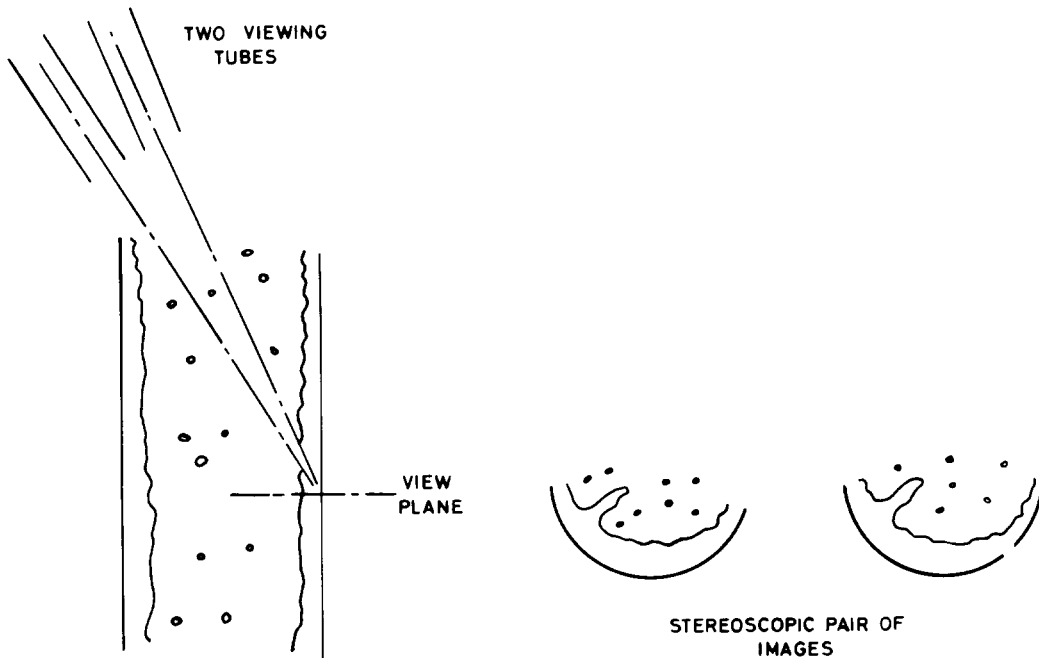

Figure 10. Stereoscopic axial view system. (Whalley *et al.* 1977.)

from the film or may have arisen from far upstream of the viewing plane. It is found, in annular flow, that entrained droplets arise almost uniquely from “disturbance waves” which traverse the liquid film and which occur at most conditions of interest. However, at very low liquid flow rates, the disturbance waves do not exist and for any gas flow rate, there is a critical liquid flow for the inception of these waves. If the liquid flow rate is set to the critical value (such that naturally occurring waves are not present) then a single artificial disturbance wave can be created by injecting a pulse of liquid around the periphery of the channel. Coupling this with the axial view technique it is possible to know the source of all droplets seen in the viewing plane and to measure the rate of entrainment associated with a single wave. Developments of this method and the associated measurements are reported by Whalley *et al.* (1977). However, even with this simplification of the flow situation, information on the radial motion of the droplets over long distances is not easily retrieved and this has led to the development of the laser shadowgraph method which we present below.

3.2 Laser shadowgraph axial view method

As was mentioned above, the earlier developments of axial view photography had the limitation of small depth of field. In the new development described here, a depth of field corresponding to the full length of the tube can, in principle, be obtained. However, in viewing the whole tube, information is lost about the axial position associated with a particular event.

A more detailed discussion of the technique is presented in a Harwell report (Whalley *et al.* 1979). Essentially, the principle employed is that of a shadowgraph. Any object in a parallel light beam will cast a shadow whose size is unaffected by the position of the object in the beam. If the wave nature of light is neglected, the object would cast a perfect in-focus shadow if the light beam were truly parallel. In practice there are two main difficulties: (i) the light beam can never be truly parallel and (ii) diffraction patterns are obtained from the objects in the light beam.

The practical optical system used is illustrated in figure 11. The light source is a 1 mW He/Ne laser which produces red light of wavelength $0.633 \mu\text{m}$. The beam is focussed by a lens (A) onto a pinhole of diameter $25 \mu\text{m}$. This pinhole is situated a distance equal to the focal length from another lens (B); hence a parallel beam of light is formed. The main purpose of the

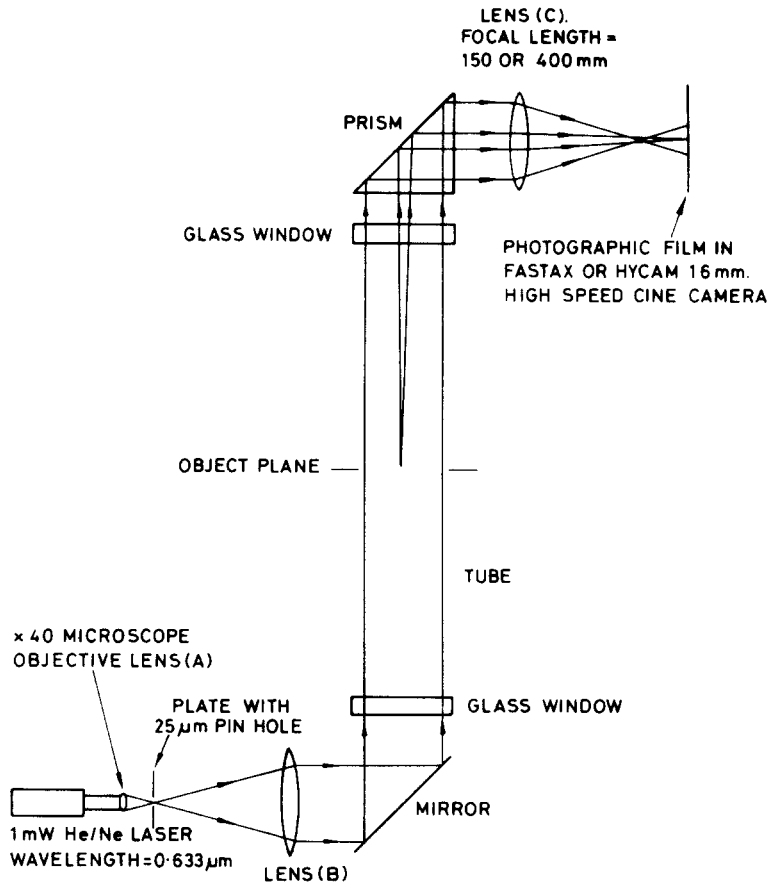

Figure 11. Parallel light technique-optical arrangement.

third lens (C) is to change the size of the shadow image from the tube diameter to a more convenient size—in this work so that the image will fit on a 16 mm cine frame. In the experiments described below, the working length of the flow tube was about 0.6 m and an acceptable image was obtained from the whole of this tube length.

A laser was used for the light source because most of the energy can be focussed through the $25\ \mu\text{m}$ aperture; this would be difficult, if not impossible, with a larger tungsten filament light source. The $25\ \mu\text{m}$ hole approximates to the ideal of an infinitely small source, thus giving a truer parallel beam.

The ends of the tube, containing the glass windows, were carefully designed so as to divert the liquid away from the windows and thus obtain an unobstructed view of the whole tube cross section. The design of both top and bottom ends was similar and is shown in figure 12. Photographs were taken using a Fastax or a Hycam high speed cine camera at 4000 frames per sec with black-and-white film.

Up to the time of writing, the technique has been applied to annular flow studies (both to the full flow situation and to the study of single waves) and also to the study of the flooding phenomenon in counter-current flow.

3.2.1 Studies of annular flow by the laser shadowgraph method. The mechanisms of droplet creation and motion in annular flow are still poorly understood. Of particular interest is the motion of the droplets subsequent to their emission from the film leading to their ultimate re-deposition on the film downstream of the point of formation from the disturbance wave. A detailed review of the experimental and analytical studies of liquid drop transport in annular flow is given by Hewitt (1978b).

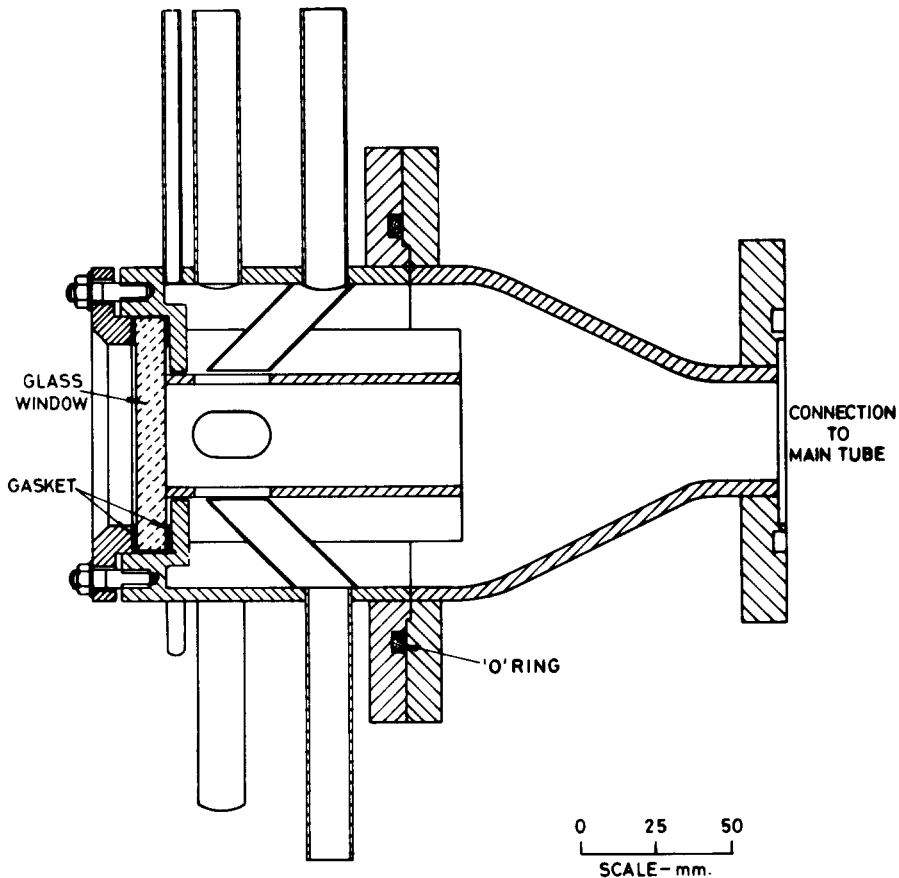

Figure 12. Cross section of viewing head for parallel light technique.

One possibility for droplet motion (and re-deposition) in the core of an annular flow is that the droplets are subject to turbulent diffusion. Thus, the turbulent eddies in the gas phase interact with the droplets and lead to a random motion which can ultimately carry the droplets to the film and cause them to redeposit. This diffusional process has been studied, for example, by Hutchinson *et al.* (1971) who took account of the difference in diffusivity between the gas and the droplets arising from the inertia of the droplets causing them to have a different motion to that of the eddies with which they were interacting. In spite of the necessarily crude assumptions in the model, a reasonable prediction of droplet deposition rate was obtained.

An alternative view of the droplet transfer phenomenon is proposed by Anderson & Russell (1970) who suggest that droplets emitted from the film leave with an initial velocity in the direction normal to the main stream velocity and that this carries them, ultimately, to impaction with the liquid film. A theoretical model for horizontal annular flow based on this concept is described by Chang (1973).

In the axial view photographs taken with small depth of field, radial motions of the droplets can be observed and, indeed, have been measured in some experiments (Langner & Mayinger 1978). However, the source of these radial motions may be either the random eddy interactions or initial velocities imparted during the process of droplet creation from the disturbance waves.

A prime purpose of the experiments reported here was to try to throw some light on this controversy. The apparatus used to obtain photographs of annular flow by the parallel light technique is shown in figure 13. The methods of introducing the air and water and the take-off points for air-water mixtures are also shown. The porous wall sections contain a 75 mm length of porous sintered brass tube of the same internal diameter (32 mm) as the perspex sections. The purge air supply was increased until the top window could be kept dry. For the films which

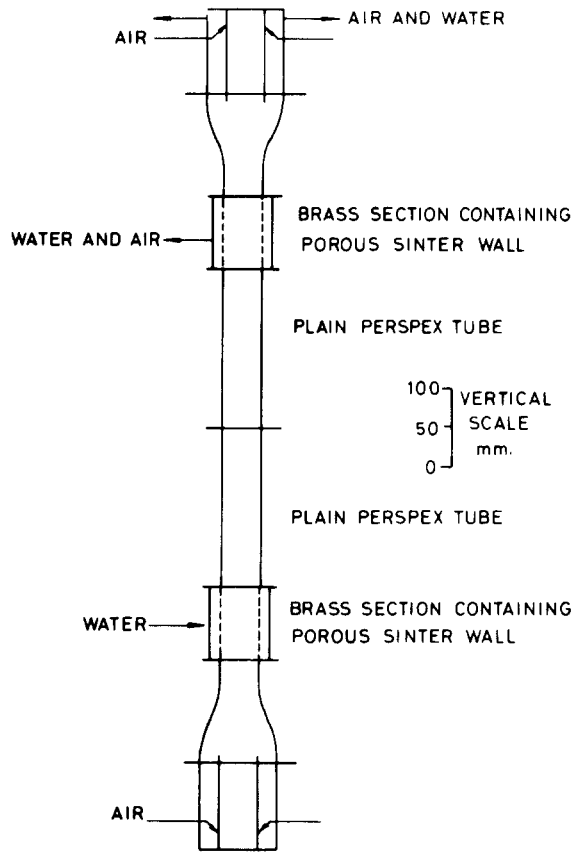

Figure 13. Schematic diagram of apparatus for photographing co-current annular flow.

were analysed in detail the mass fluxes (mass flow rate/total tube cross sectional area) were $15 \text{ kg/m}^2\text{s}$ for the water and $29 \text{ kg/m}^2\text{s}$ for the air. Experiments were also carried out with single injected waves. The pressure in the tube was only slightly greater than atmospheric.

A reasonable image was obtained from the whole length of the tube. The flow rates used were fairly modest, but if a larger water flow rate is used then the number of liquid drops in the gas flow becomes too large to distinguish individual drops. This problem would of course be magnified with a longer tube, though the use of single injected waves would alleviate the difficulty. The waves on the liquid film could clearly be seen and with the flow rates used only one wave was usually present in the tube at once. Larger flow rates would give confusing images because a number of waves are being observed simultaneously. Even though the flow rates are modest, the air velocity in the tube is around 24 m/s .

The most usual mechanism of drop formation is illustrated schematically in figure 14: the drops arise from the fragmentation of a filament. This filament in turn is the remnant of a bubble blown by the air as it undercuts the wave. The drops were often emitted with considerable radial velocities.

The drop radial motion could be seen clearly; most of the drops seemed to move in straight lines. The main exceptions were either very slow moving drops which often showed a curved trajectory or drops in the top viewing section which were deflected by the strong air jets keeping the window dry. The drops which could be observed were only the large ones: drops of diameter $250 \mu\text{m}$ and above could be followed in detail from frame to frame, smaller drops could be seen on the cine film running at normal projection speeds but could not be followed from frame to frame. The smaller drops were visible sometimes as normal images and sometimes as diffraction rings (only the first ring of the diffraction pattern system was visible). The

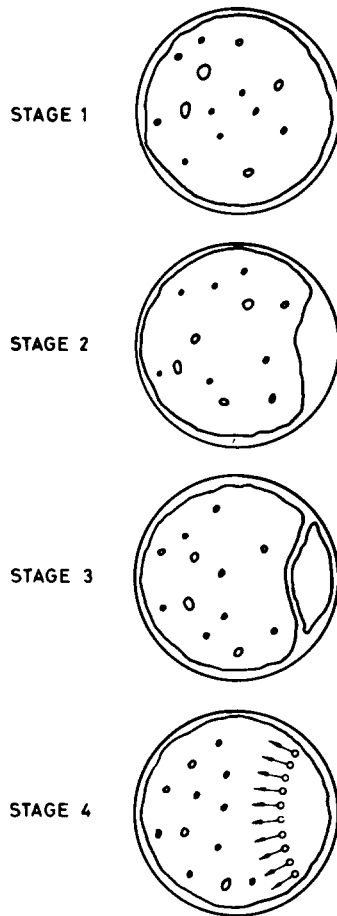

Figure 14. Usual mechanism of droplet formation.

drop size calculated from the diffraction ring size agreed well with the direct measurement of drop diameter for drops where image type changed as the drop moved along the tube.

Detailed analysis of drop motion was obtained from frame-by-frame analysis of the film. From the film speed and the drop positions, the velocity of the drop normal to the main flow could be calculated. Figure 15 shows examples of the actual trajectories.

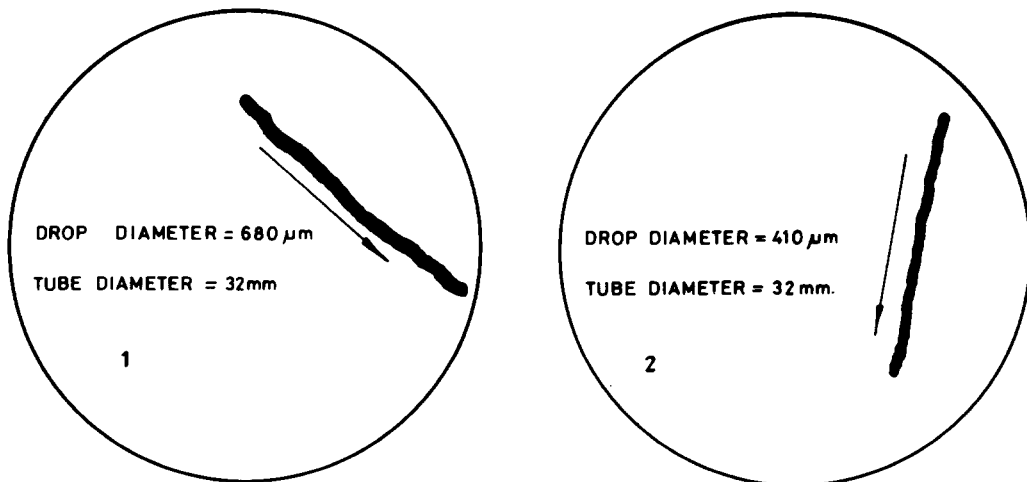

Figure 15. Drop trajectories (arrow indicates direction of motion, drops are drawn as circles to the same scale as the tube diameter).

A straight line was fitted through the trajectory of the centre of each drop by a least squares method and the maximum deviation from this straight line found. The ratio of the maximum deviation to the drop diameter is usually around unity indicating that the trajectory does not differ significantly from a straight line.

The average non-axial velocities of the drops seems, for the cases studied, to be fairly random, but the maximum velocity was of the order of 1 m/s. This seems, at first sight, to be a considerable velocity, but it is worth noting that if the drop is travelling with the same velocity as the gas, the drop will have travelled an axial distance of 0.8 m whilst it traverses a diameter of the tube.

The measured drop velocity from successive frames of the cine film is subject to large errors because of the small distance moved at the high framing rate used. A reasonable average velocity over 10 frames of the film can be obtained. These short time averages were examined but no significant trends could be observed. The results for one of the drops examined in detail is shown in figure 16.

The experiments show clearly that the droplets that can be observed using the laser shadowgraph technique (the larger droplets) are entrained with a significant velocity normal to the direction of flow, and that this velocity persists with little deceleration until the point of redeposition of the droplet. The droplet appears to travel in a straight line and to be relatively unaffected by the gas phase eddies. It thus seems certain, therefore, that this mechanism of droplet transfer is the dominant one for large droplets. However, the smaller droplets would be more susceptible to interactions with the gas phase eddies and the random defusional process could still be appropriate for them.

It thus seems that both the proposed mechanisms are likely to be significant and their relative importance needs to be investigated. Further studies using the laser shadowgraph method are proceeding in an attempt to quantify the contribution to deposition by the larger droplets thus leading to an estimate of the significance of deposition of smaller droplets, which cannot be observed using this technique.

3.2.2 Studies of flooding using the laser shadowgraph technique. Counter-current gas-liquid flow (with the liquid falling in the form of a liquid film down the wall of the channel and with the gas flowing upwards) is common in many practical applications. For instance, it is found in reflux condensers in the process industry, it is found in certain postulated fault conditions in nuclear reactors and it is important in counter-current mass transfer operations. As the gas flow is increased, at a given liquid rate, a condition known as "flooding" is encountered. Here, the liquid phase interacts with the gas phase, leading to liquid transport above the point of introduction of the liquid. At high gas rates, none of the liquid phase moves downwards and

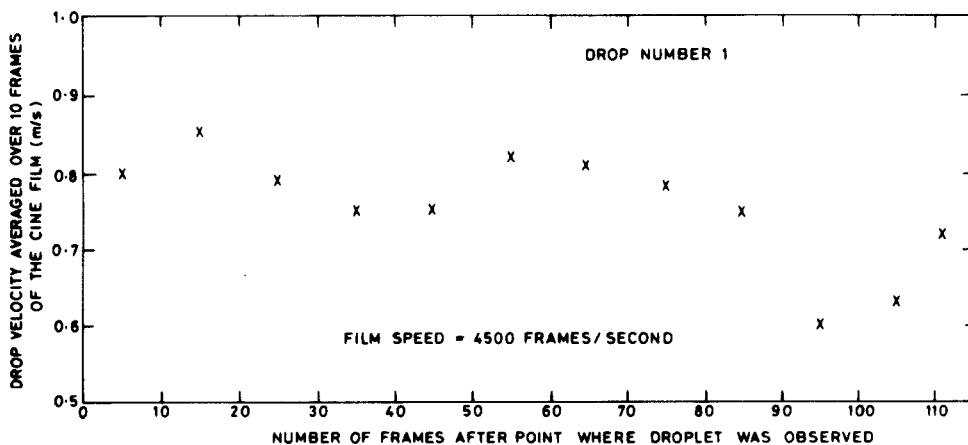

Figure 16. Variation of drop velocity across the tube with time (for trajectory see figure 15).

co-current upwards annular flow is achieved. The transition from complete liquid downflow to partial liquid up-flow is defined as flooding and has been studied very widely. However, there is still considerable controversy about the precise mechanism.

The "classical" picture of flooding is one of rapid wave growth on the falling film leading to partial or complete bridging of the channel with subsequent transport of the liquid above the injection point. Mechanisms for the sudden growth of waves have been proposed, e.g. by Shearer & Davidson (1965) and by Wallis & Kuo (1976).

The classical picture of flooding taking place as a result of wave bridging was rejected by Dukler & Smith (1976). They ascribe the flooding phenomenon to the onset of liquid droplet entrainment from the waves present on the film-gas interface. By making assumptions on the nature of these waves, it was possible to obtain predictions of the flooding rate.

Previous mechanistic studies of the flooding phenomenon (Hewitt & Wallis 1963 and Hewitt *et al.* 1965) show that continuous wave growth occurs down the liquid film but that there is little or no change in the mean film thickness until just before the flooding phenomenon. The results are not sufficiently specific to decide between the two alternative mechanisms, though it was suggested that the wave growth mechanism of Shearer & Davidson (1965) was the more likely. In the experimental studies of Shearer and Davidson, the waves studied were formed at a specific point within the duct by accelerating the gas phase at that point. In a constant area duct, the waves are likely to be transported down the tube and, if they are extracted before the waves can grow sufficiently to cause partial or complete bridging, then the flooding would not take place. This explains the influence of length on flooding found in the experiments of Hewitt *et al.* (1965). However, the data could also be consistent with the mechanisms proposed by Dukler & Smith (1976).

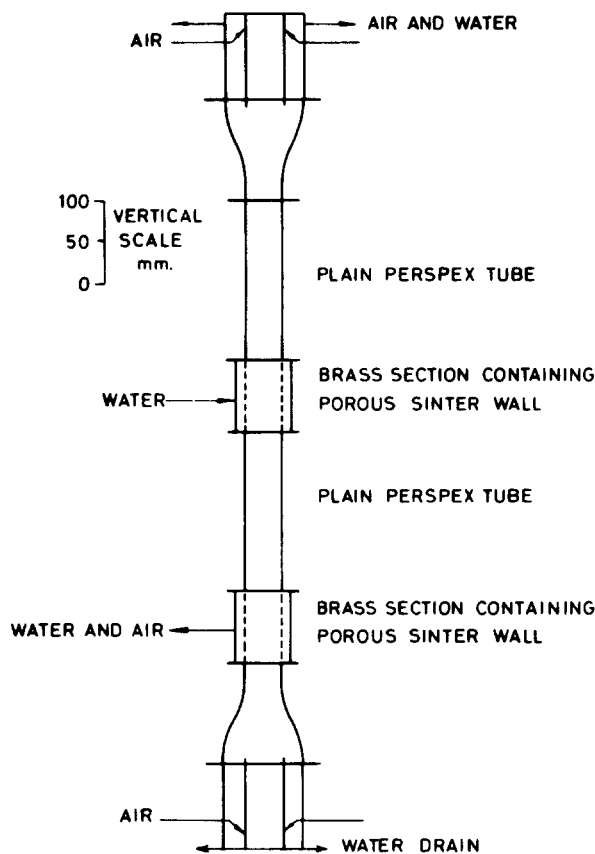

Figure 17. Schematic diagram of apparatus for photographing flooding.

The objective of the present experiments using the axial shadowgraph technique was to try to distinguish between the two mechanisms.

The apparatus used to obtain photographs of flooding by the parallel light technique is shown in figure 17. The pipe sections used in the annular flow studies were used again with some slight re-arrangement. Air and water were again used. The mass flux for the water was $35 \text{ kg/m}^2\text{s}$ and flooding occurred when the air mass flux was $12.5 \text{ kg/m}^2\text{s}$. This corresponds to a value of the constant C in the correlation of Wallis (1961) of 1.05, which agrees reasonably with data for a test section with similar length and injection system obtained by Hewitt & Wallis (1963).

The cine films were taken with the following procedure. The conditions were adjusted until the air flow rate was just below that for flooding and then whilst the camera was running, the air flow rate was increased by about 5%. This caused flooding to occur and with practice the onset of flooding could be made to occur about half way through the film which took about 4 sec to run through the camera. A typical sequence of events is shown in figure 18 where tracings of the gas-liquid interface have been taken from the cine film at intervals of 100 frames. This corresponds to a time interval of 25 ms. After a quiescent period disturbances rapidly build up.

The cine-films show that the interfacial disturbance grows rapidly from an initial protruberance. The wave grows until it occupies a large fraction of the cross-sectional area of the tube. The point at which the wave starts around the circumference varies from experiment to experiment and, since the phenomenon is very sensitive to liquid flow rate, preferential growth at a given point probably arises from very small variations in liquid flow rate around the periphery. These variations are likely to occur in all practical falling film systems, though every effort was made in these present experiments to maintain uniform flow by having the tube precisely vertical and injecting the liquid uniformly around the periphery.

When the growing wave occupies a substantial proportion of the cross section of the tube, the gas flow bursts through it causing entrainment of droplets in a manner not dissimilar to that observed in annular flow and illustrated in figure 14. However, in annular flow, the wave amplitudes are much smaller and the bursting phenomenon is much less marked.

It will be seen, therefore, that flooding does, indeed, correspond to a rapid wave growth phenomenon, though growth can take place preferentially from one side of the channel. A consequence of the wave growth is wave bursting and the formation of droplets and these droplets may be carried upwards in the gas stream as observed by Dukler and Smith. The large waves themselves may also be driven upwards by the gas flow.

It would seem, therefore, that the wave growth and droplet mechanisms are not mutually exclusive. The first is the cause of flooding and the second an effect of flooding.

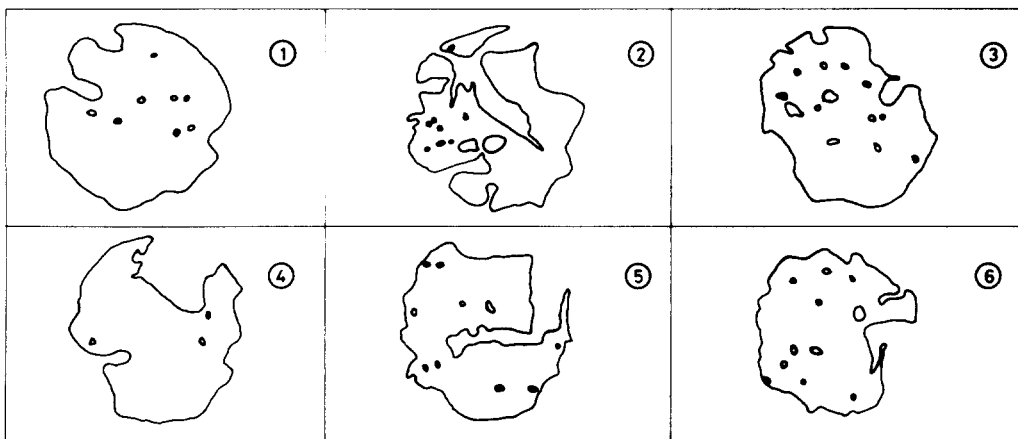

Figure 18. Wave growth in flooding in counter-current air-water flow (Interval between pictures is 25 ms.)

4. CONCLUSIONS

The following main conclusions emerge from this review:

(1) Very rapid progress has been made (particularly over the past five years) in local laser-based optical methods in two phase flow systems. Much further development is possible in these methods and their application to local velocity, particle size, concentration and temperature measurement is likely to increase.

(2) Advanced photographic methods still have much to offer in helping to explain two phase flow phenomena. In this presentation, we have shown how these methods can be used to discriminate local mechanisms in fully developed annular flow and in flooding in counter-current flow.

However, it must be emphasised that sophisticated experimental techniques are of no particular value unless they are employed in intelligently designed experiments. These techniques should not be regarded as an end in themselves.

REFERENCES

- ANDERSON, R. J. & RUSSELL, T. W. F. 1970 Circumferential variation of interchange in horizontal annular two-phase flow. *Indust. Engng Chem. Fund.* **9**, 340–344.
- ARNOLD, C. R. & HEWITT, G. F. 1967 Further developments in the photography of two-phase gas-liquid flow. AERE-R 5318.
- AZZOPARDI, B. J., FREEMAN, G. & WHALLEY, P. B. 1978 Drop sizes in annular two-phase flow. AERE-R 9074.
- BEGLEY, R. F., HARVEY, A. B., BYER, R. L. & HUDSON, B. S. 1974 A new spectroscopic technique: coherent anti-Stokes Raman spectroscopy. *American Laboratory* November 1974.
- CHANG, D. R. C. 1973 Generation, movement and deposition of droplets in annular two-phase flow. Ph.D thesis, University of Delaware.
- CONY, M. W. E. & FISHER, S. A. 1976 Instrumentation for two-phase flow in use or under development at the Central Electricity Research Laboratories. European Two-Phase Flow Group Meeting, Erlangen, Germany.
- DUKLER, A. E. & SMITH, L. 1976 Two-phase interactions in counter-current flow studies of the flooding mechanism. Summary Rep. 1 (Contract AT (49-24) 0194) to U.S. Nuclear Regulatory Commission.
- FARMER, W. M. 1972 Measurement of particle size, number density, and velocity using a laser interferometer. *Appl. Opt.* **11**, 2603–2612.
- FISHER, S. A. & YU, S. K. W. 1974 Dryout in serpentine evaporators. *Int. J. Multiphase Flow* **1**, 771–791.
- FISHER, S. A., HARRISON, G. S. & PEARCE, D. L. 1978 Instrumentation for localised measurements with fast response gas/vapour flows. Symposium on measurements in Polyphase Flows. ASME Winter Annual Meeting, San Francisco.
- HEWITT, G. F. 1978a *Measurement of Two-phase Flow Parameters*. Academic Press, London.
- HEWITT, G. F. 1978b Liquid mass transport in annular two-phase flow. International Seminar on Momentum, Heat and Mass Transfer in Two-Phase Energy and Chemical Systems, Dubrovnik, Yugoslavia.
- HEWITT, G. F. & ROBERTS, D. N. 1969 Investigation of interfacial phenomena in annular two-phase flow by means of the axial view technique. AERE-R 6070.
- HEWITT, G. F. & WALLIS, G. B. 1963 Flooding and associated phenomena in falling film flow in a vertical tube. AERE-R 4022.
- HEWITT, G. F., LACEY, P. M. C. & NICHOLLS, B. 1965 Transitions in film flow in a vertical tube. Paper presented at Symposium on Two-Phase Flow, Exeter, U.K., Paper B4; see also AERE-R 4614.
- HUTCHINSON, P., HEWITT, G. F. & DUKLER, A. E. 1971 Deposition of liquid or solid dispersions from turbulent gas streams: a stochastic model. *Chem. Engng Sci.* **26**, 419–439.

- LANGNER, H. 1978 Studies of entrainment behaviour in steady and transient two-phase annular flow. Thesis T. U. Hannover, Germany.
- LANGNER, H. & MAYINGER, F. 1978 Entrainment mass flow measurements in annular two-phase flow. International Seminar on Momentum, Heat and Mass Transfer in Two-Phase Energy and Chemical Systems. Dubrovnik, Yugoslavia.
- LEE, R. S. L. & SRINIVASAN, J. 1978 An experimental investigation of dilute two-phase dispersed flow using LDA technique. In *Proceedings of 1978 Heat Transfer and Fluid Mechanics Institute*. Strandford Univ. Press. Calif.
- NIBLER, J. W., McDONALD, J. R. & HARVEY, A. B. 1976 CARS measurement of vibrational temperature in electric discharges. *Optics Commun.* **18**, 71.
- REGINER, P. 1973 Application of coherent anti-Stokes Raman scattering to the measurement of gas concentrations and to flow visualisation. European Space Agency Rep. ESA-TT-200.
- REGNIER, P., MOYA, F. & TARAN, J. P. E. 1974 Gas concentration measurement by coherent Raman anti-Stokes scattering. *AIAA J.* **12**, 826.
- SCHMIDT, E. W., BOIARSKI, A. A., GIESEKE, J. A. & BAINES, R. H. 1976 Applicability of laser interferometry technique for drop size determination. Paper presented at *Symp. Am. Chem. Soc.*, San Francisco.
- SHEARER, C. J. & DAVIDSON, J. F. 1965 The investigation of a standing wave due to gas blowing upwards over a liquid film: its relation to flooding in wetted wall columns. *J. Fluid Mech.* **22**, 321-335.
- SUZUKI, S. & UEDA, T. 1977 Behaviour of liquid films and flooding in counter-current two-phase flow—I. Flow in circular tubes. *Int. J. Multiphase Flow* **3**, 517-532.
- SWITHENBANK, J., BEER, J. N., TAYLOR, D. S., ABBOT, D. & MCCREATH, G. C. 1976 A laser diagnostic for the measurement of droplet and particle size distribution. Univ. Sheffield, Dept. of Chemical Engineering and Fuel Technology Report.
- WALLIS, G. B. 1961 Flooding velocities for air and water in vertical tubes. AEEW-R123.
- WALLIS, G. B. & KUO, J. T. 1976 The behaviour of gas-liquid interfaces in vertical tubes. *Int. J. Multiphase Flow* **2**, 521-536.
- WHALLEY, P. B., AZZOPARDI, B. J., PSHYK, L. & HEWITT, G. F. 1977 Axial view photography of waves in annular two-phase flow. European Two-Phase Flow Group Meeting, Grenoble, France.
- WHALLEY, P. B., HEWITT, G. F. & TERRY, J. W. 1979 Photographic studies of two-phase flow using a parallel light technique. AERE-R 9389.
- WIGLEY, G. 1978 The sizing of large drops by laser anemometry. *J. Phys. E. Sci. Instrum.* **11**, 639-642.
- WILLIAMS, D. R. & STENHOUSE, I. A. 1978 Laser Raman gas diagnostic techniques. AERE-R 9071.